

# FACE MACHINING

## PICCO CUT For Face Grooving

PICCO CUT face grooving mini-bars for minimum bore diameter of 6 mm.

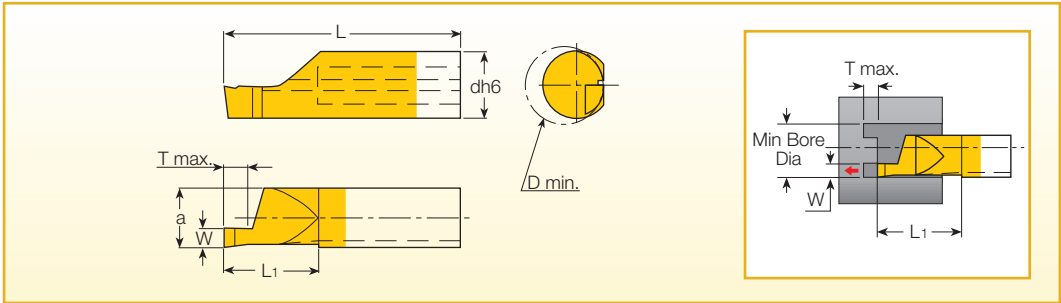

### PICCO R/L 010...

Designation	dh6	W	a	L1	L	Tmax	Min. Bore Dia.	Holder
PICCO R/L 010.1006-10	5.0	1.0	4.2	11	26	1.5	6.0	PICCO 12-4-5
PICCO R/L 010.1506-10	5.0	1.5	4.2	11	26	2.0	6.0	PICCO 16-4-5 PICCO 20-4-5
PICCO R/L 010.1008-10 <sup>(1)</sup>	7.0	1.0	5.9	11	26	1.5	8.0	PICCO 16-6-7 PICCO 20-6-7
PICCO R/L 010.1508-10 <sup>(1)</sup>	7.0	1.5	5.9	11	26	2.5	8.0	
PICCO R/L 010.2008-10 <sup>(1)</sup>	7.0	2.0	5.9	11	26	3.0	8.0	
PICCO R/L 010.2508-10	7.0	2.5	5.9	11	26	3.5	8.0	
PICCO R/L 010.3008-10	7.0	3.0	5.9	11	26	3.5	8.0	
PICCO R/L 010.1008-20	7.0	1.0	5.9	21	35	1.5	8.0	
PICCO R/L 010.1508-20	7.0	1.5	5.9	21	35	2.5	8.0	
PICCO R/L 010.2008-20	7.0	2.0	5.9	21	35	3.0	8.0	
PICCO R/L 010.2508-20 <sup>(1)</sup>	7.0	2.5	5.9	21	35	3.5	8.0	
PICCO R/L 010.3008-20 <sup>(1)</sup>	7.0	3.0	5.9	21	35	3.5	8.0	
PICCO R/L 010.1008-30	7.0	1.0	5.9	30	45	1.5	8.0	PICCO 16-6-7 PICCO 20-6-7
PICCO R/L 010.1508-30	7.0	1.5	5.9	30	45	2.5	8.0	
PICCO R/L 010.2008-30	7.0	2.0	5.9	30	45	3.0	8.0	
PICCO R/L 010.2508-30	7.0	2.5	5.9	30	45	3.5	8.0	
PICCO R/L 010.3008-30	7.0	3.0	5.9	30	45	3.5	8.0	

<sup>(1)</sup> Right hand only, available as standard. (Kit Items-see below).

Carbide bars are PVD coated in grade IC228.

For holders see ISCAR TURN PLUS Catalog.

### PICCO CUT Kit SET-4R

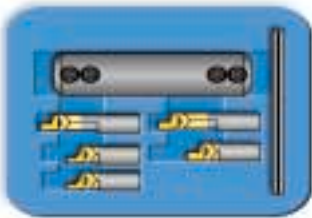

This PICCO CUT Kit contains:  
Marked (1) items in above table  
and PICCO 16-6-7 holder.

# FACE MACHINING

## PICCO R/L 610 for Passport Holder: MG PCO...

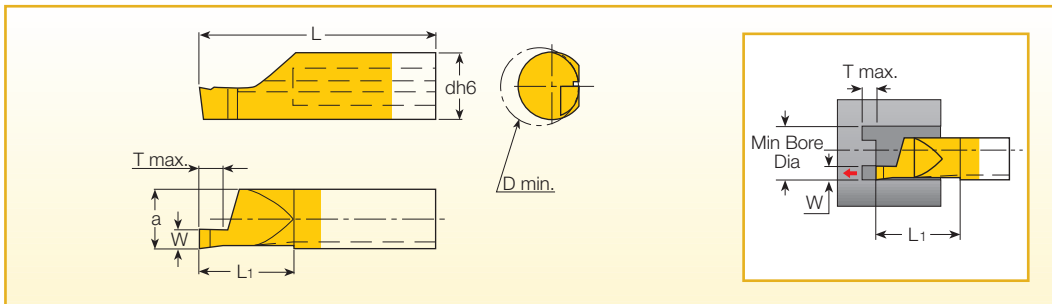

Designation	W	a	L1	L	dh6	Tmax.	Min. bore Dia.
R/L 610.1008-10	1.0	5.2	11	26	6.0	1.5	8.0
R/L 610.1508-10	1.5	5.2	11	26	6.0	2.5	8.0
R/L 610.2008-10	2.0	5.2	11	26	6.0	3.0	8.0
R/L 610.2508-10	2.5	5.2	11	26	6.0	3.5	8.0
R/L 610.3008-10	3.0	5.2	11	26	6.0	3.5	8.0
R/L 610.1008-20	1.0	5.2	20	35	6.0	1.5	8.0
R/L 610.1508-20	1.5	5.2	20	35	6.0	2.5	8.0
R/L 610.2008-20	2.0	5.2	20	35	6.0	3.0	8.0
R/L 610.2508-20	2.5	5.2	20	35	6.0	3.5	8.0
R/L 610.3008-20	3.0	5.2	20	35	6.0	3.5	8.0

All mini-bars are PVD coated in IC228 grade.

For holders see ISCAR TURN PLUS Catalog.

